

PHOTODIODE DETECTOR

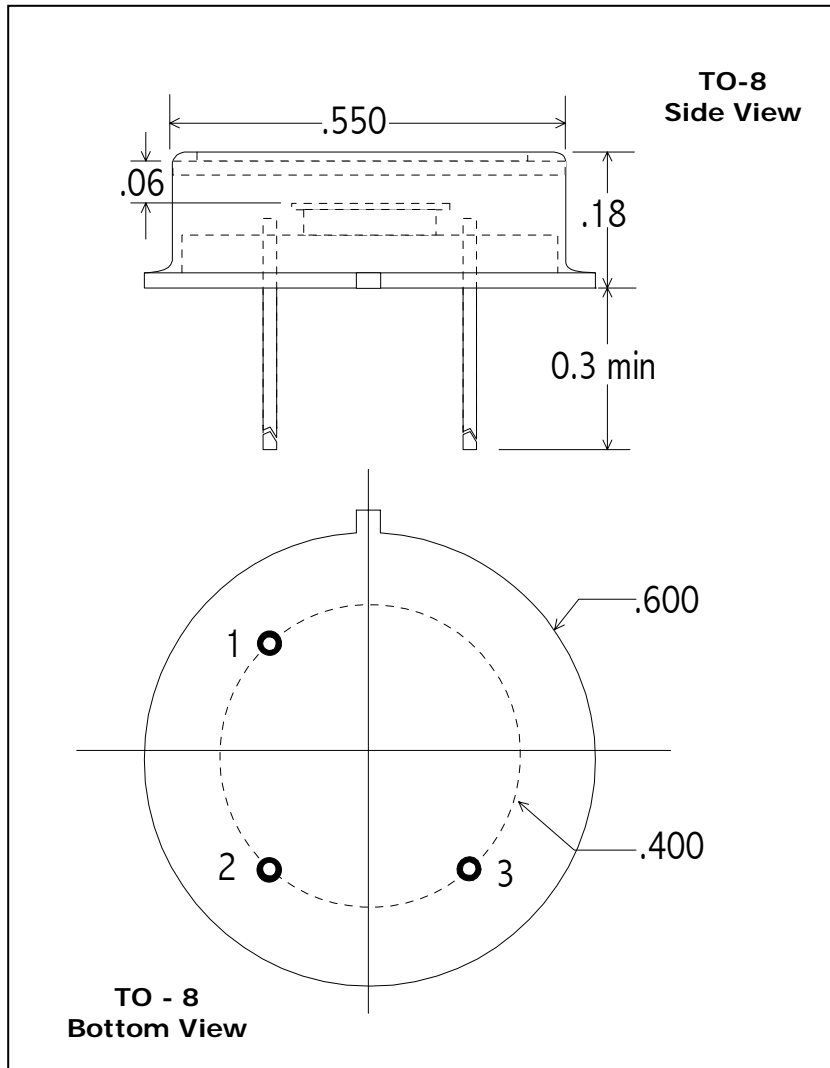

Part No: G-050

PIN OUT

- 1 = ANODE
- 2 = CASE
- 3 = CATHODE

Note: Dimensions in inches

Operating Note

ELECTRO OPTICAL SYSTEMS offers room temperature photodiode detectors. The units have state-of-the-art sensitivity and may be supported by accessories such as optical filters (longpass and bandpass), integral preamplifiers, and infrared source assemblies. These units find applications in industrial control systems, gas analyzers, thermal sensors, and general infrared instrumentation.

SPECIFICATIONS – G-050 Germanium Photodiode

Active Diameter (mm)	5
Operating Wavelength (μm)	0.8 – 1.8
Shunt Resistance (Ω)	10k min ; 15k typ
Shunt Capacitance (pF)	30000 typ
Responsivity (A/W)	0.9 @ 1.50 μm
NEP (W/Hz ^{1/2})	< 1.5 x 10 ⁻¹² @ 1.50 μm