

## TE - SERIES PHOTODIODE / RECEIVER

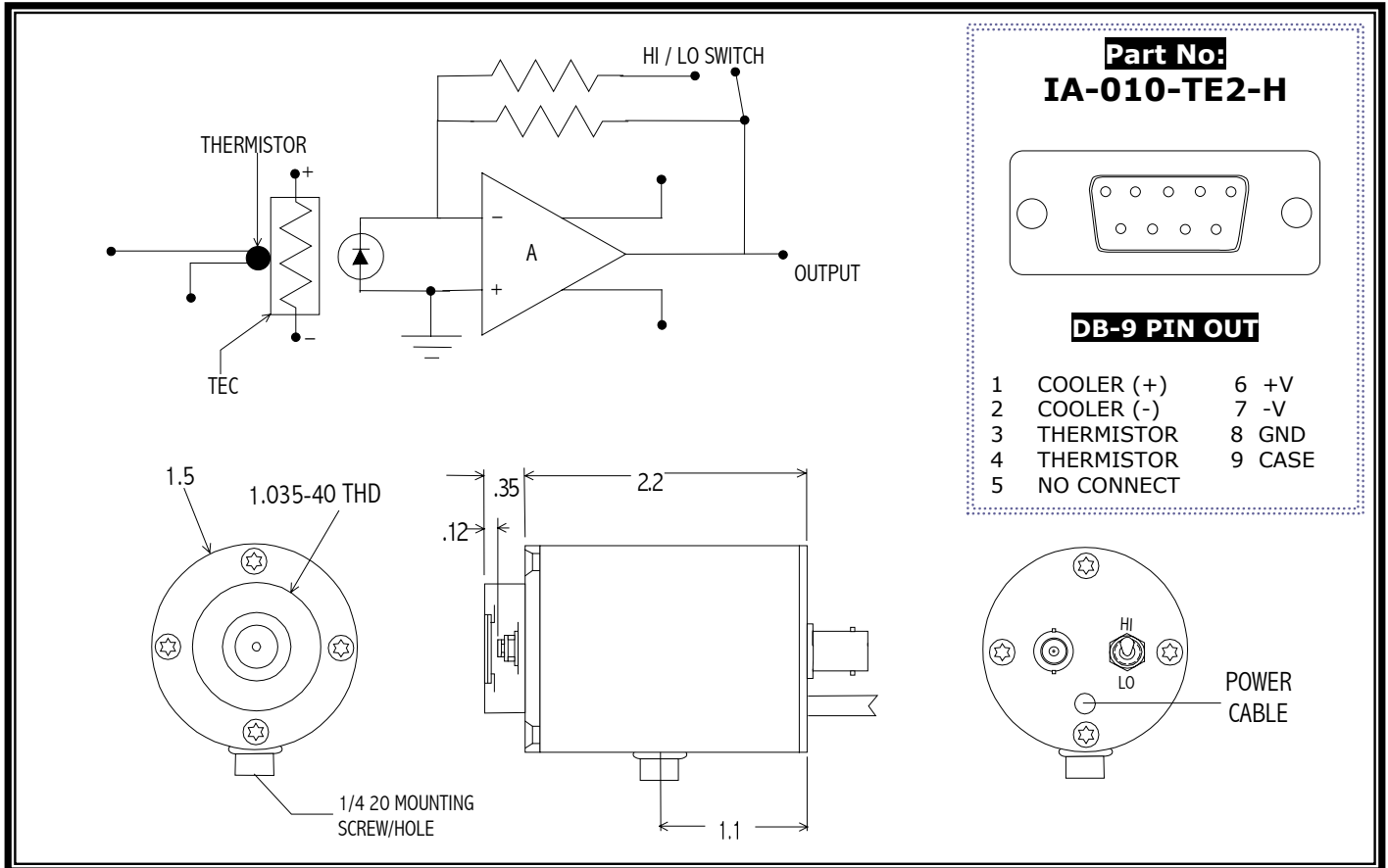

**Application Note** This unit is a high performance photodiode/receiver operated with a thermoelectric cooler for stabilization/cooling with a dual gain FET input transimpedance amplifier. The output voltage is proportional to the input signal current:  $V_{out} = I_{signal} \cdot R_f$ . The PD/AMP is a DC coupled dual gain system. Care should be taken in shielding the unit from stray light during operation to prevent saturation of the amplifier (and potential failure).

## SPECIFICATIONS

Detector Type	1.0 mm InAs Photodiode	
Operating Temperature- °C	22 @ $I_{tec} = 0.0$ A	-30 @ $I_{tec} = 0.5$ A
Operating Wavelength- $\mu$ m	1.0 – 3.5	1.0 – 3.4
Responsivity- V/W @ pk	$0.8 \times 10^4 / 0.8 \times 10^3$	$2.1 \times 10^4 / 2 \times 10^3$
Noise- V/Hz <sup>1/2</sup>	$2.4 \times 10^{-7} / 10^{-8}$	$6.3 \times 10^{-8} / 10^{-9}$
NEP- W/Hz <sup>1/2</sup> pk	$3 \times 10^{-11}$	$3 \times 10^{-12}$
Bandwidth (-3dB)- Hz	DC – 22k / 100k Hz+	DC – 22k / 100k Hz+
Power Requirements	+/- 9 VDC to +/- 15 VDC	
Connections	BNC signal output. Shielded power cable terminated with a DB-9 connector directly couples the unit with the PS/TC -1 Low Noise Power Supply.	