

IA - SERIES PHOTODIODE

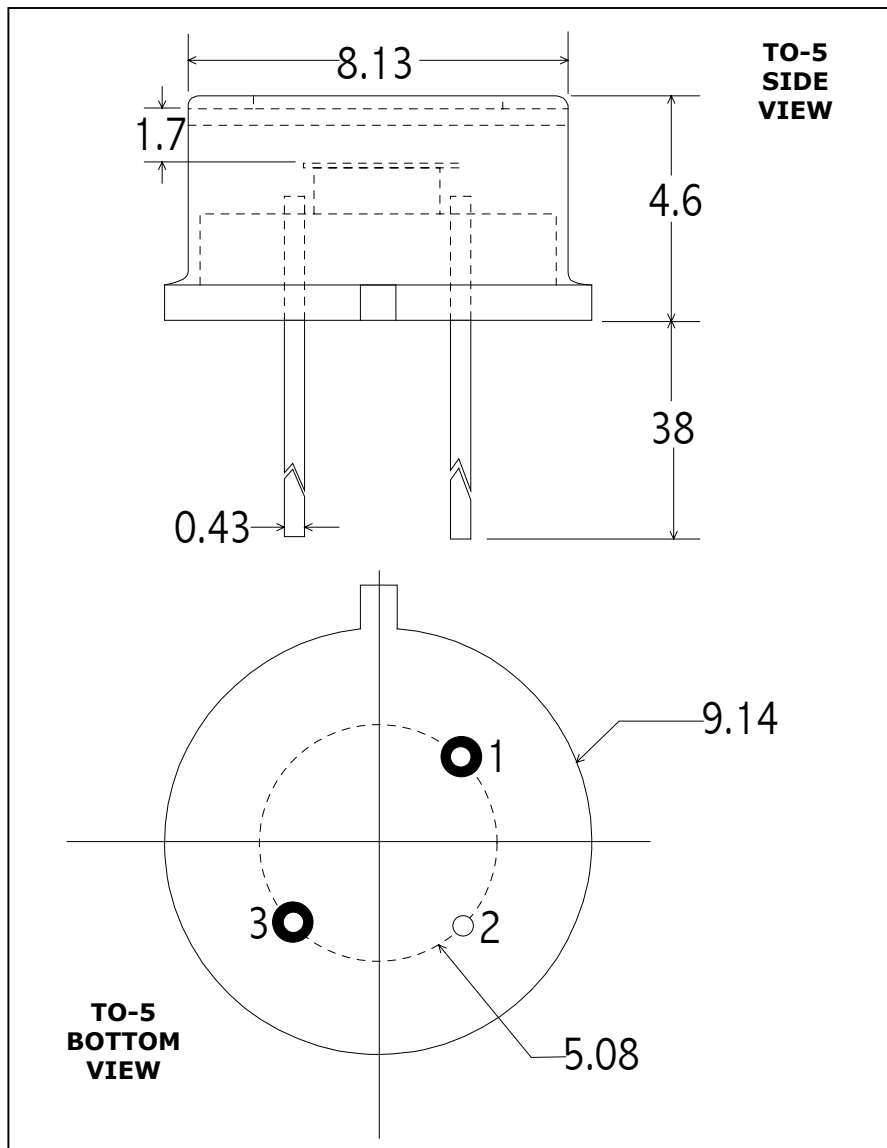

Part No: IA-020

PIN OUT

- 1 = ANODE
- 2 = CASE
- 3 = CATHODE

Note:

Dimensions in millimeters

Application Note

ELECTRO OPTICAL SYSTEMS offers room temperature InAs photodiode detectors for operation in the 1.0 - 3.5 μm spectral range.

The units have state-of-the-art sensitivity and may be supported by accessories such as optical filters (longpass and bandpass), integral preamplifiers, and infrared source assemblies. These units find applications in industrial control systems, gas analyzers, thermal sensors, and general infrared instrumentation.

SPECIFICATIONS

Active Diameter (mm)	2.0
Operating Temperature ($^{\circ}\text{C}$)	22
Operating Wavelength	1.0 - 3.4
Shunt Resistance (Ω) typ	≥ 10
Shunt Capacitance (pF)	1200. nom
Responsivity @ 3.2 μm (A/W)	0.8 typ
NEP @ 3.2 μm ($\text{W}/\text{Hz}^{1/2}$)	5.5×10^{-11}