

TO - STYLE PHOTODIODE / AMPLIFIER

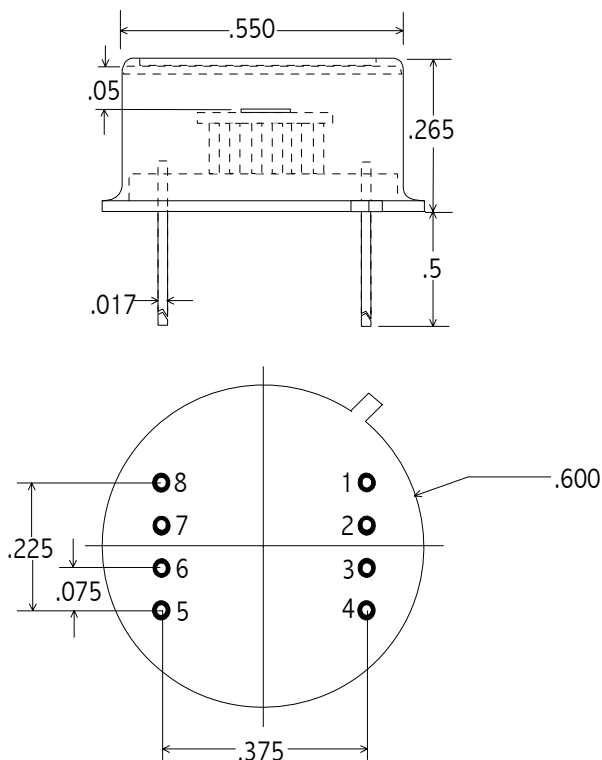

Part no:

IGA - 020 - E8

PIN OUT

- 1 = Offset Adj
- 2 = Inv In / Photodiode Cathode
- 3 = N-Inv In / Photodiode Anode
- 4 = -V
- 5 = Gain Select
- 6 = Output
- 7 = +V
- 8 = Offset Adj

Note: Dimensions in Inches

Operating Note This unit is a high performance photodiode/transimpedance amplifier unit. The output voltage is equal to the optical signal power multiplied by the photodiode responsivity in A/W and the feedback resistance in ohms. The unit is DC-coupled and should be shielded from stray or room lights to avoid saturation of the amplifier.

SPECIFICATIONS

Operating Temperature (°C)	24
Active Area	2 mm dia
Photodiode Shunt Resistance (MΩ)	10 min
Photodiode Shunt Capacitance (pF)	400. nom
Responsivity @ 1.3 μm (V/W)	$0.9 \times 10^8 / 10^7$ *
NEP (100Hz, 1.3 μm) (W/Hz ^{1/2})	$< 5 \times 10^{-14}$
Bandwidth (Hz)	DC - 2000 *
Offset Voltage (mV)	< 3.

* **Note:** Other gain/bandwidth values can be specified