

CRYOGENIC RECEIVERS

Part No: IGA-030-E-LN6N

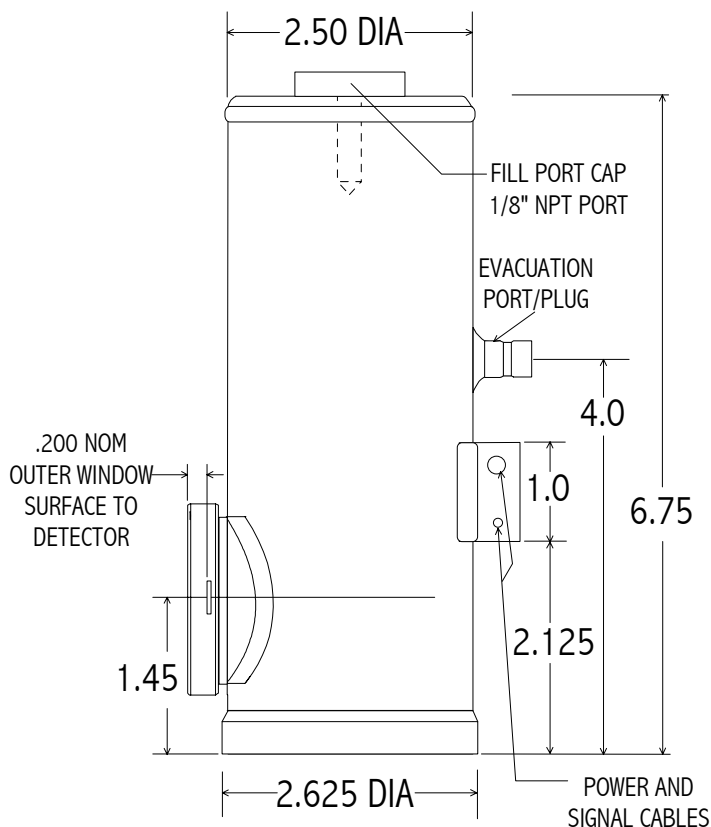

Operating Note

This unit is a high performance cryogenically operated InGaAs photodiode/amplifier designed for low frequency DC or chopped measurements. The output voltage is proportional to radiation incident on the active area as follows:

$$V_{out} = P_{sig} \times R_{\lambda} \times R_f$$

where P_{sig} is incident power in watts, R_{λ} is the photodiode responsivity in A/W at the wavelength of interest, and R_f is the amplifier transimpedance gain. This is DC coupled with high gain and extensive care should be taken in shielding the unit from any ambient light during operation. Exposure to room lights may cause amplifier saturation and can lead to failure of the unit.

SPECIFICATIONS

Active Area	3 mm diameter
Spectral Range	1000 – 1700 nm @ 298K; 1000 - 1500 nm @ 77K
Shunt Resistance	> 5 MΩ @ 298K; > 1000 MΩ @ 77K
Shunt Capacitance	1000 pF typical
NEP	< 5 x 10⁻¹⁴ W/Hz^{1/2} @ 298K; < 1.5 x 10⁻¹⁵ W/Hz^{1/2} @ 77K
Responsivity @ 1.3 μm	0.8 A/W minimum, 0.9 A/W typical
Dewar Hold Time	12 hours minimum with liquid N₂
Field of View	60° nominal
Amplifier	Dual-Gain Transimpedance
Gain	1 x 10¹⁰ V/A / 1 x 10⁹ V/A
Bandwidth	DC – 30 / 300 Hz
Connections	BNC signal coaxial cable with 3 lead shielded power cable. Red = +V, Black = -V, White/Shield = ground Note: A DB9 connector is provided on units purchased with optional PS-1 Low Noise Power Supply