

## IGA - SERIES PHOTODIODE

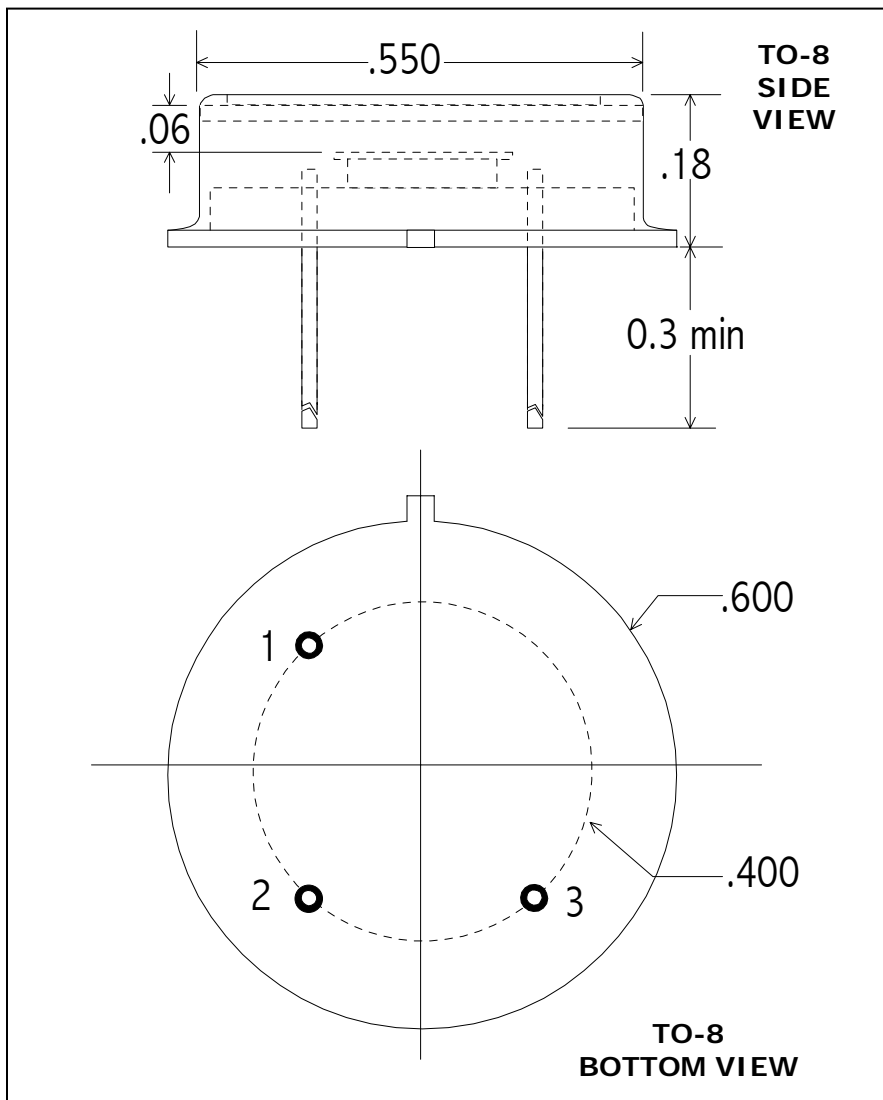

### Part No:

**IGA-050**

### PIN OUT

- 1 = ANODE
- 2 = CASE
- 3 = CATHODE

### Note:

Dimensions in inches

## Application Note

**ELECTRO OPTICAL SYSTEMS** offers room temperature photodiode detectors. The units have state-of-the-art sensitivity and may be supported by accessories such as optical filters (longpass and bandpass), integral preamplifiers, and infrared source assemblies. These units find applications in industrial control systems, gas analyzers, thermal sensors, and general infrared instrumentation.

## SPECIFICATIONS

Active Diameter (mm)	5
Operating Wavelength ( $\mu\text{m}$ )	0.8 – 1.7
Shunt Resistance ( $\Omega$ )	250k min ; 500k typ
Shunt Capacitance (pF)	2000 typ
Responsivity (A/W)	0.9 @ 1.30 $\mu\text{m}$
NEP ( $\text{W}/\text{Hz}^{1/2}$ )	$< 3.0 \times 10^{-13}$ @ 1.3 $\mu\text{m}$