

IGA - SERIES DETECTOR

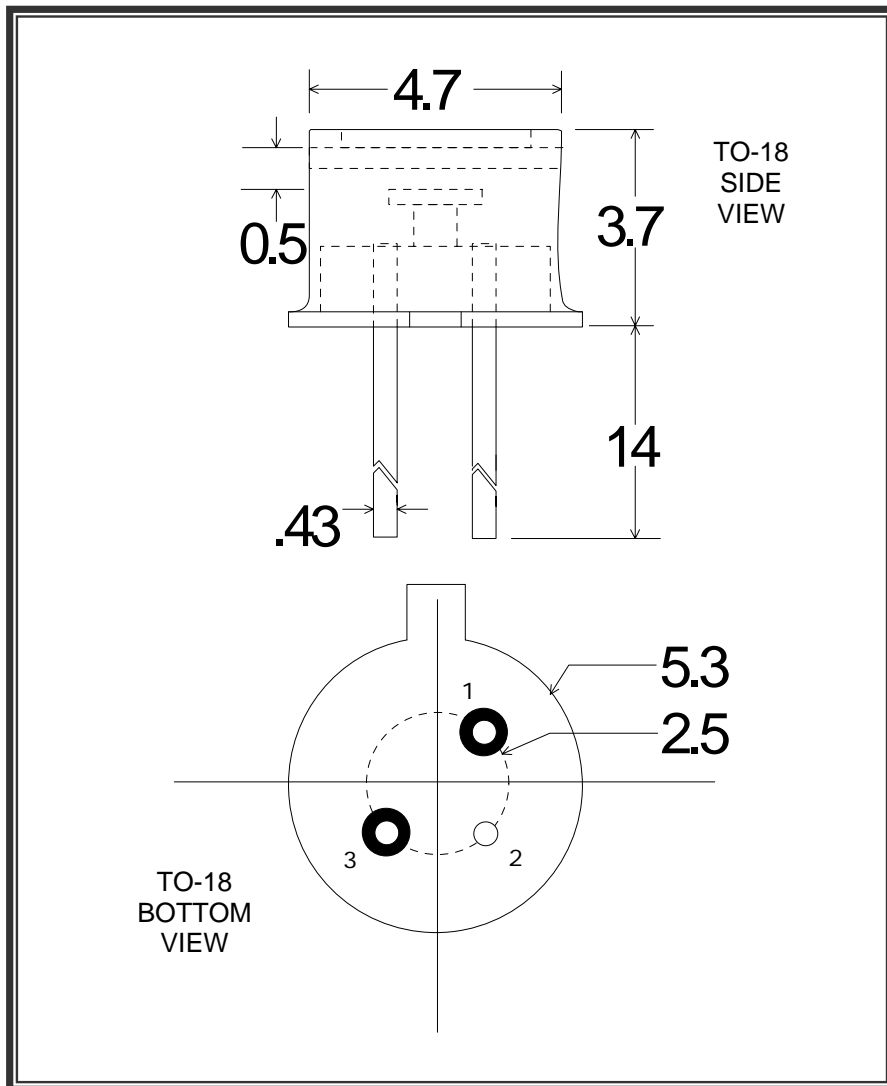

Part no: IGA2.2 - 003

PIN OUT

- 1 = CATHODE
- 2 = CASE
- 3 = ANODE

Note:

Dimensions in millimeters

Application Note

ELECTRO OPTICAL SYSTEMS offers room temperature InGaAs photodiode detectors for operation in the 1.0 – 1.7 μm spectral range. The units have state-of-the-art sensitivity and may be supported by accessories such as optical filters (longpass and bandpass), integral preamplifiers, and fiber optic connectors. These units find applications in industrial control systems, gas analyzers, thermal sensors, and general fiber optic test instrumentation.

SPECIFICATIONS

Active Diameter (mm)	.30
Operating Temperature ($^{\circ}\text{C}$)	22
Operating Wavelength	1.2 – 2.6
Shunt Resistance ($\text{k}\Omega$)	30 min
Shunt Capacitance (pF)	40 typ
Responsivity @ 2.2 μm (A/W)	1.1
NEP @ 1.3 μm ($\text{W}/\text{Hz}^{1/2}$)	$< 7.0 \cdot 10^{-13}$

RoHS COMPLIANT