

CRYOGENIC PHOTODIODE / AMPLIFIER

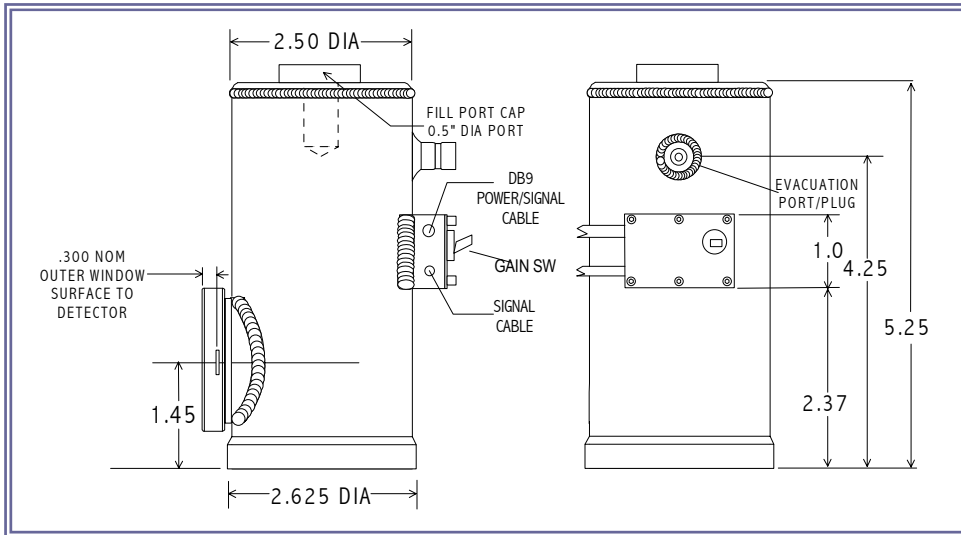

Part no:
IGA2.2-010-E-LN4

Operating Note

This unit is a high performance cryogenically operated photodiode / receiver. The output voltage is proportional to radiation incident on the active area as follows:

$$V_{out} = P_{sig} \times R_l \times R_f$$

where P_{sig} is incident power in watts, R_l is the photodiode responsivity in A/W at the wavelength of interest, and R_f is the amplifier transimpedance gain. The unit is DC coupled, and extensive care should be taken in shielding from any ambient light during operation. Exposure to room lights may cause amplifier saturation and can lead to failure of the unit.

PIN OUT

Connector: DB9

- 1 = n/c
- 2 = n/c
- 3 = n/c
- 4 = n/c
- 5 = n/c
- 6 = +V
- 7 = -V
- 8 = GND
- 9 = CASE

Cable: Signal BNC

Note: For units ordered without PS-1 power supply, flying leads are provided color-coded as:

- RED = +V**
- BLACK = -V**
- WHITE/SHIELD = GND**

SPECIFICATIONS

Active Area	1 mm diameter
Spectral Range	1100 - 2600 nm @ 298 K; 1100 - 2400 nm @ 77K
Shunt Resistance	3 kΩ typ @ 298K, >2 MΩ @ 77K
Shunt Capacitance	200 pF typical @ 298 K
Responsivity @ 2.2 μm (x R _f = 10 ⁹ /10 ⁸)	1.1 A/W typical @ 298 K
Dewar Hold Time	8 hours minimum with liquid N ₂
Field of View	60° nominal
Amplifier	Dual Gain Transimpedance
Bandwidth	DC - 100 Hz typ
NEP @ 2.2 μm, 100 Hz	< 4.0 x 10 ⁻¹⁴ W/Hz ^{1/2}