

TE - COOLED PHOTODIODE

Part No: IGA2.2-010-TE2

PIN OUT

- 1 = COOLER (-)
- 2 = THERMISTOR
- 3 = THERMISTOR
- 4 = COOLER (+)
- 5 = DETECTOR CATHODE
- 6 = DETECTOR ANODE
- 7 = NO CONNECT
- 8 = NO CONNECT

Note:

Dimensions in inches

Operating Note

The TE cooled photodiode series consists of a high performance photodiode mounted on a thermoelectric cooler, all housed in a TO-8 package. A thermistor is mounted to the TEC's cold plate to provide a precise, reliable temperature monitor. Before operation VERIFY ELECTRICAL WIRING, else catastrophic damage may be sustained by the unit. Electrical power consumption can exceed 2.5 Watts (2V / 1.25A); therefore, this package must be suitably heat sunk. Thermal grease with secure clamping is recommended for power dissipation. Temperature levels below -45°C are possible with an optimized mechanical assembly.

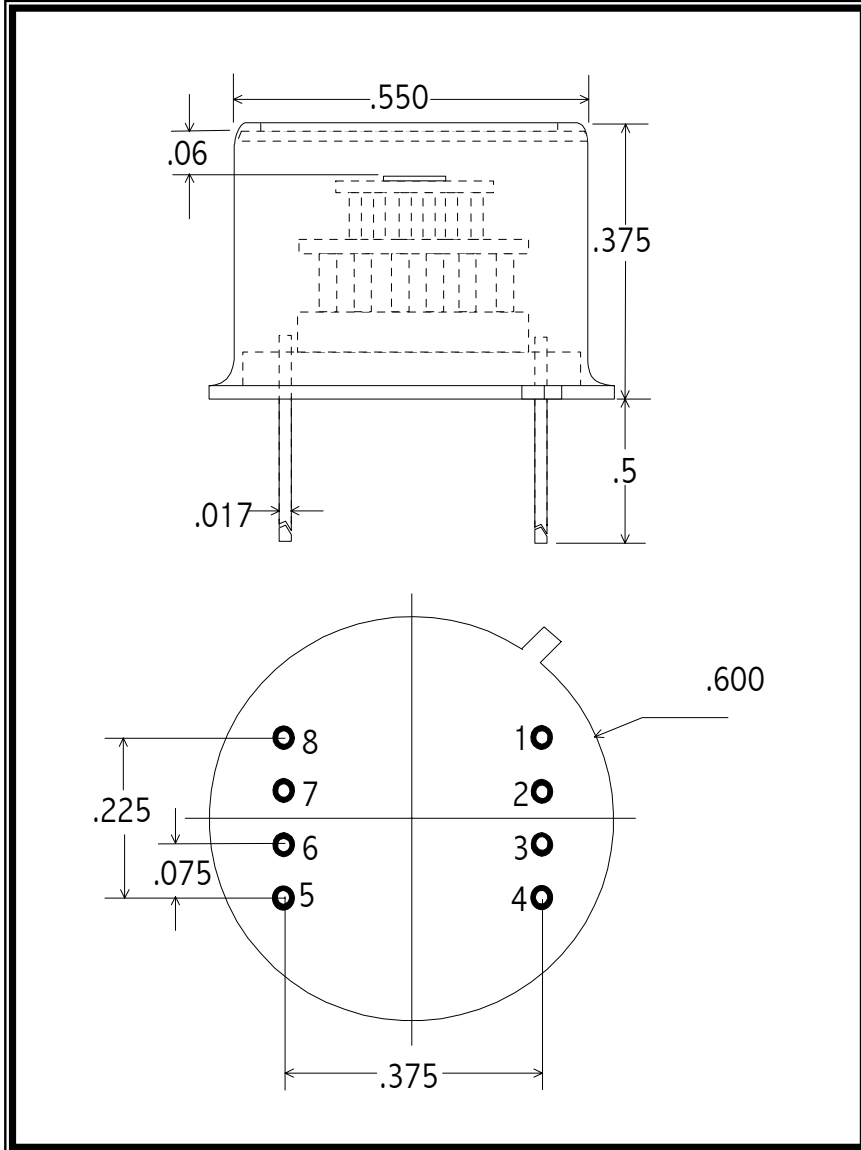

SPECIFICATIONS

Detector Type	1mm DIA extended InGaAs (TE-Cooled)	
Operating Temperature (°C)	22	-30
Shunt Resistance (kΩ)	3 typ	60 typ
Shunt Capacitance (pF), typ	120	120
Responsivity @ 2.2 μm (A/W)	1.0	1.0
Thermistor Resistance (kΩ) typ	1.5 typ	40.0 typ
Cooler Current (A) typ	0.00	0.60 TYP.
Maximum Cooler Current (A)	1.25	