

2 - COLOR PHOTODIODE

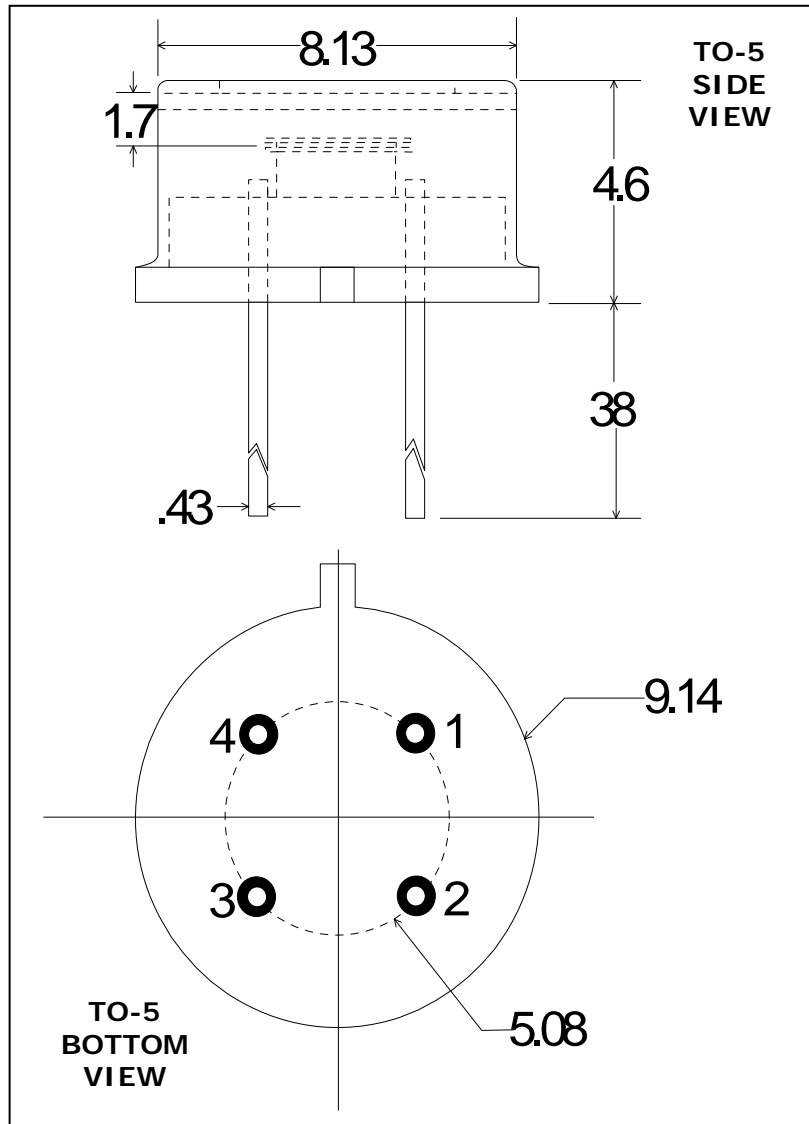

Part No: IGA / IGA - 020

PIN OUT

- 1 = TOP CATHODE
- 2 = TOP ANODE
- 3 = BOTTOM ANODE
- 4 = BOTTOM CATHODE

Note:
Dimensions in millimeters

Application Note

ELECTRO OPTICAL SYSTEMS offers a variety of room temperature 2-color photodiode detectors. The units have state-of-the-art sensitivity and are supported by accessories such as optical filters, integral preamplifiers, and fiber optic connectors.

These units find applications in industrial control systems, test equipment, thermal sensors, and general infrared instrumentation.

SPECIFICATIONS

Detector Position	TOP	BOTTOM
Detector Type	InGaAs Photodiode	InGaAs Photodiode
Active Diameter (mm)	2.0	2.0
Operating Wavelength (μm)	0.9 – 1.7	1.7
Shunt Resistance (Ω), 0V	10M min @ 0V	10M min @ 0V
Shunt Capacitance (pF)	500 typ	500 typ
Responsivity (A/W)	0.9 @ 1300 nm	0.05 @ 1750 nm
NEP (W/Hz ^{1/2})	< 5 x 10 ⁻¹⁴ @ 1.3 nm	< 1 x 10 ⁻¹² @ 1.75 nm