

## IS SERIES CRYOGENIC PHOTODIODE/AMPLIFIER

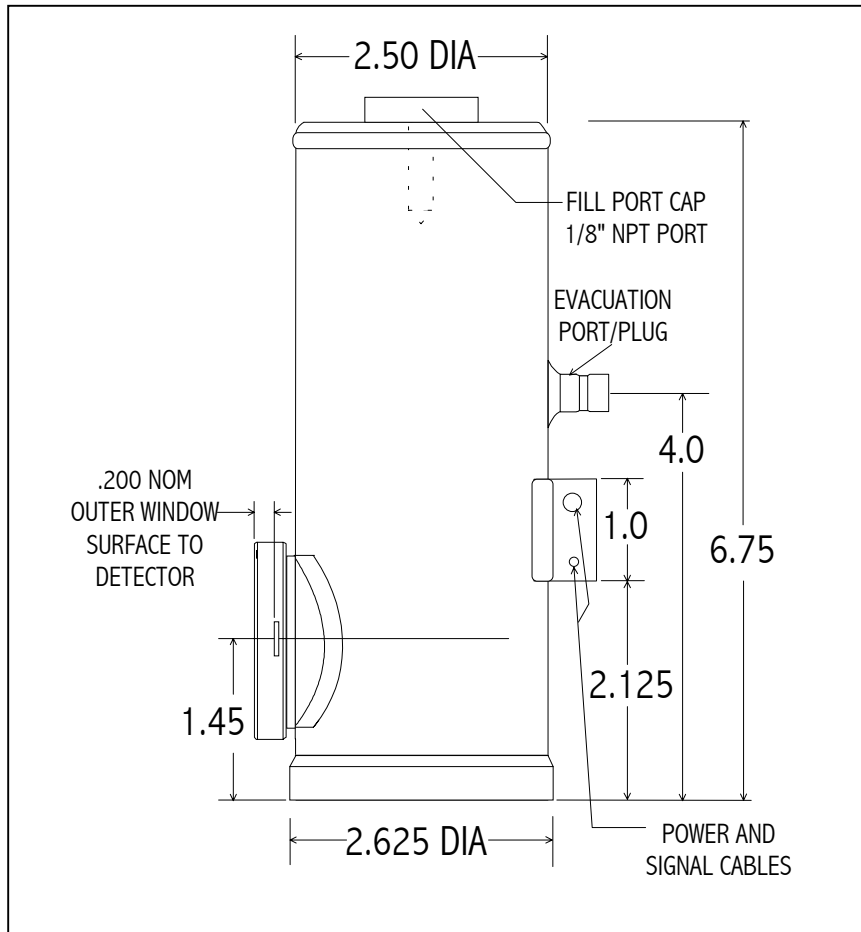

**Part No:**

**IS-020-E-LN6N**

### Application Note

This unit is a high performance cryogenically operated InSb photodiode/amplifier designed for low frequency DC or chopped measurements. The output voltage is proportional to radiation incident on the active area as follows:

$$V_{out} = P_{sig} \times R_{\lambda} \times R_f$$

where  $P_{sig}$  is incident power in watts,  $R_f$  is the photodiode responsivity in A/W at the wavelength of interest, and  $R_f$  is the amplifier transimpedance gain. This is DC coupled with high gain and extensive care should be taken in shielding the unit from any ambient light during operation. Exposure to room lights may cause amplifier saturation and can lead to failure of the unit

### SPECIFICATIONS

<b>Active Area</b>	<b>2 mm diameter</b>
<b>Spectral Range</b>	<b>1.0 – 5.5 <math>\mu\text{m}</math></b>
<b>Shunt Resistance</b>	<b>&gt; 200 K<math>\Omega</math> @ 77K</b>
<b>Shunt Capacitance</b>	<b>1200 pF typical</b>
<b>NEP</b>	<b>&lt; 1.5 x 10<sup>-12</sup> W/Hz<sup>1/2</sup> @ 77K</b>
<b>Responsivity @ 5.3 <math>\mu\text{m}</math></b>	<b>10<sup>5</sup> / 10<sup>4</sup> V/W @ amp out</b>
<b>Dewar Hold Time</b>	<b>12 hours minimum with liquid N<sub>2</sub></b>
<b>Field of View</b>	<b>60° nominal</b>
<b>Amplifier</b>	<b>Dual-Gain Transimpedance</b>
<b>Bandwidth</b>	<b>DC – 2500 Hz</b>
<b>Connections</b>	<b>BNC signal coaxial cable with 3 lead shielded power cable. Red = +V, Black = -V, White/Shield = ground <b>Note:</b> A DB9 connector is provided on units purchased with optional PS-1 Low Noise Power Supply</b>