

IS SERIES CRYOGENIC PHOTODIODE/AMPLIFIER

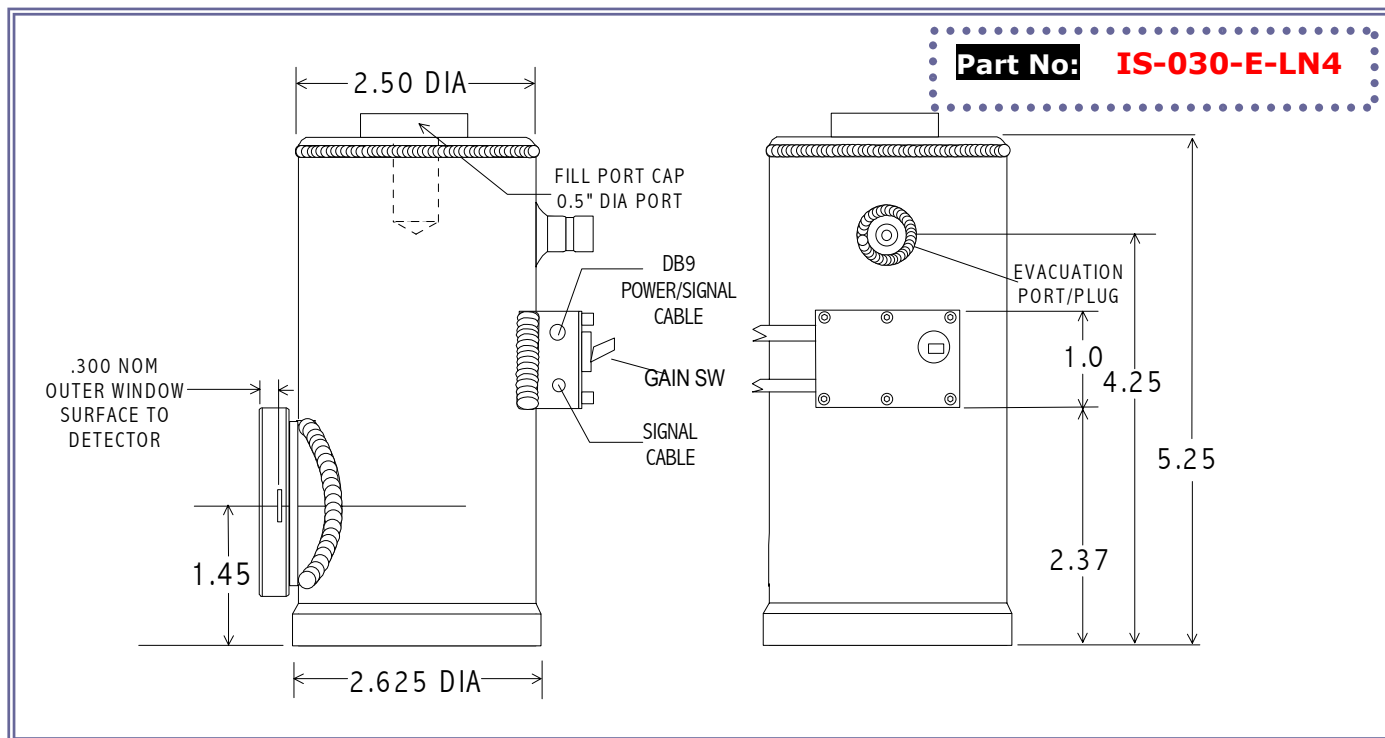

Application Note This unit is a high performance cryogenically operated InSb photodiode/amplifier designed for low frequency DC or chopped measurements. The output voltage is proportional to radiation incident on the active area as follows: $V_{out} = P_{sig} \times R_f \times R_f$ where P_{sig} is incident power in watts, R_f is the photodiode responsivity in A/W at the wavelength of interest, and R_f is the amplifier transimpedance gain. This is DC coupled with high gain and extensive care should be taken in shielding the unit from any ambient light during operation. Exposure to room lights may cause amplifier saturation and can lead to failure of the unit.

SPECIFICATIONS

Active Area	3 mm diameter
Spectral Range	1.0 – 5.5 μm
Shunt Resistance	> 200 K Ω @ 77K
Shunt Capacitance	1200 pF typical
Detectivity (p_k , 1kHz, 1Hz)	> 1.2×10^{11} cm-Hz ^{1/2} /W
Responsivity @ 5.3 μm	5×10^4 / 10^3 V/W @ amp out
Dewar Hold Time	8 hours minimum with liquid N ₂
Field of View	60° nominal
Amplifier	Dual-Gain Transimpedance
Bandwidth	DC – 2500 Hz
Connections	BNC signal coaxial cable with 3 lead shielded power cable. Red = +V, Black = -V, White/Shield = ground Note: A DB9 connector is provided on units purchased with optional PS-1 Low Noise Power Supply