

MCT - SERIES PHOTOCONDUCTORS

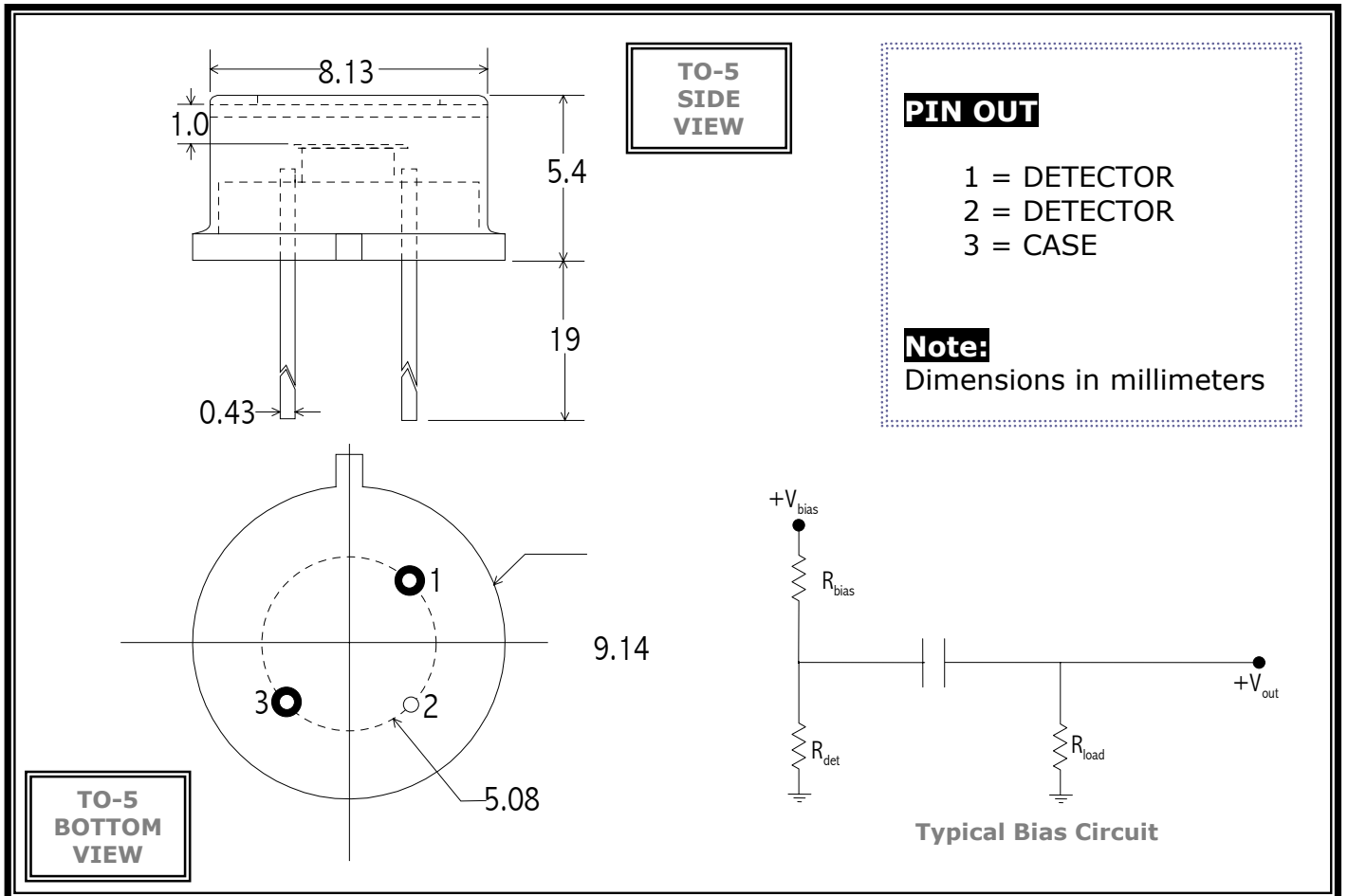

Application Note Electro-Optical Systems Inc, offers room temperature photoconductive detectors. The units have state-of-the-art sensitivity and may be supported by accessories such as optical filters (longpass and bandpass), integral preamplifiers and infrared source assemblies. These units find applications in industrial control systems, gas analyzers, thermal sensors, and general infrared instrumentation.

SPECIFICATIONS

Part Number	MCT4.5-010	MCT5.0-010
Active Area	1mm x 1mm	
Operating Wavelength	1 - 4.5 μm typ	1 - 5 μm typ
Peak Wavelength	4.2 μm typ	4.5 μm typ
Dark Resistance (Ω)	50 - 200	
Time Constant	1 - 5 μs	
Bias Current	10 mA typ	
Responsivity @ λ_p (V/W)	200 typ	100 typ
D^* @ λ_p ($\text{cm Hz}^{1/2} / \text{W}$)	1×10^{10} min	5×10^9 min