

TE COOLED PBS - SERIES PHOTOCONDUCTOR

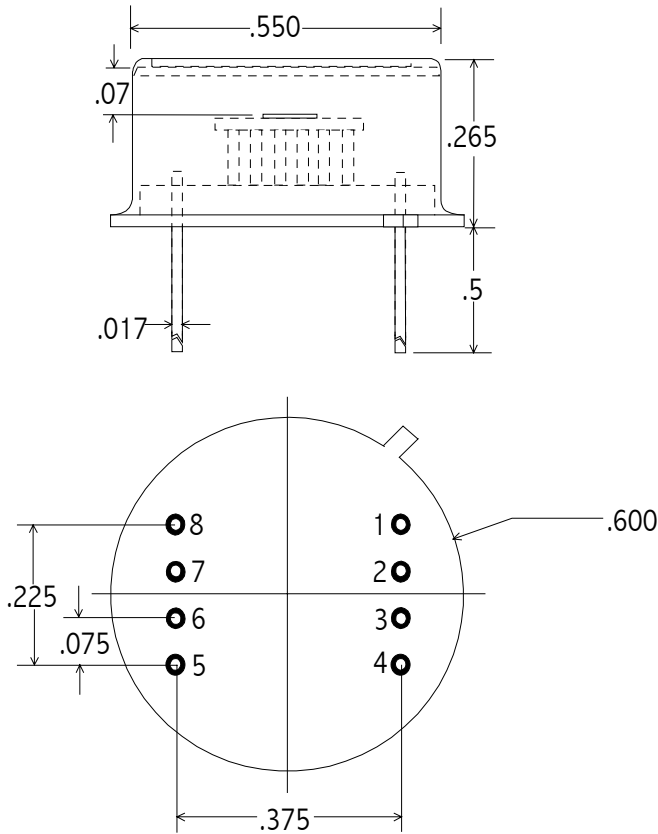

Part no.

PBS-050-TE1

PIN OUT

- 1 = COOLER (-)
- 2 = THERMISTOR
- 3 = THERMISTOR
- 4 = COOLER (+)
- 5 = DETECTOR
- 6 = DETECTOR
- 7 = NO CONNECT
- 8 = NO CONNECT

Note:

Dimensions in Inches

Operating Note

The TE cooled photodetector series consists of a high performance photoconductor mounted on a thermoelectric cooler, all housed in a TO-8 package. A thermistor is mounted to the TEC's cold plate to provide a precise, reliable temperature monitor. Before operation VERIFY ELECTRICAL WIRING, else catastrophic damage may be sustained by the unit. Electrical power consumption can exceed 1 watt (1V / 1.00A); therefore, this package must be suitably heat sunk. Thermal grease with secure clamping is recommended for power dissipation. Temperature levels below -10°C are possible with an optimized mechanical assembly.

SPECIFICATIONS

Operating Temperature ($^{\circ}\text{C}$)	22	-10
Active Area	5 mm x 5 mm PBS Photoconductor	
Detector Resistance (Ω), typ	0.5 - 2.0 M	0.7 - 4.0 M
Responsivity (2.6 μm) V/W,	$> 0.5 \times 10^5$	$> 1 \times 10^5$
D^* (2.6 μm ,500Hz,1Hz) $\text{cm}\cdot\text{Hz}^{1/2}/\text{W}$	$> 6 \times 10^{10}$	$> 1.5 \times 10^{11}$
Thermistor Resistance (k Ω)	1.7 nom	7.5 nom
Cooler Current (A)	0.0	0.65
Maximum Cooler Current (A)	1.00	