

TO-STYLE PHOTODETECTOR / AMPLIFIER

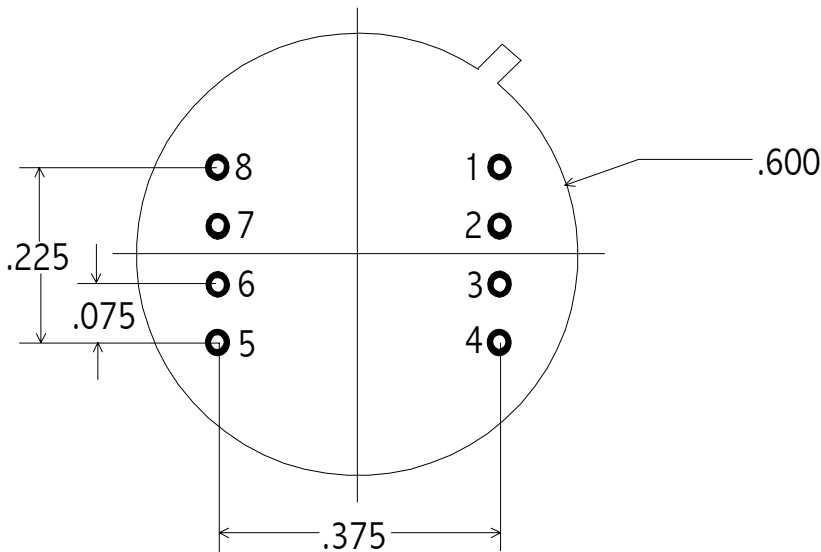
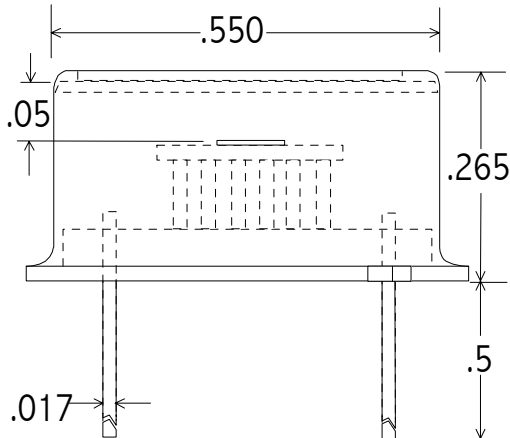

PIN OUT

- 1 = n/c
- 2 = Inv In
- 3 = GND
- 4 = -V
- 5 = Gain Select
- 6 = Output
- 7 = +V
- 8 = n/c

Note: Dimensions in Inches

APPLICATION NOTE

These units are high performance photoconductor / receiver modules operated at ambient temperature with a dual gain voltage amplifier. The detector's bias voltage is linked to the amplifier power supply and no additional biasing is necessary. The PC/AMP is an AC coupled dual gain detector system requiring a modulated input signal for operation.

SPECIFICATIONS @ 23° C NOM

Part Number	PBSE - 010 - E8	PBSE - 020 - E8	PBSE - 030 - E8	PBSE - 050 - E8
Active Area	1 mm x 1 mm	2 mm x 2 mm	3 mm x 3 mm	5 mm x 5 mm
Operating Wavelength - μm	1.0 - 4.5	1.0 - 4.5	1.0 - 4.5	1.0 - 4.5
Responsivity - V/W @ pk	1×10^6	5×10^5	3×10^5	2×10^5
Noise - V/Hz ^{1/2}	3×10^{-5}	2.5×10^{-5}	3×10^{-5}	5×10^{-5}
NEP - W/Hz ^{1/2} @ pk	$< 3 \times 10^{-11}$	$< 5 \times 10^{-11}$	$< 1 \times 10^{-10}$	$< 2.5 \times 10^{-10}$
Bandwidth (-3dB) - Hz	5 - 10 kHz	5 - 10 kHz	5 - 10 kHz	5 - 10 kHz
Power Requirements	+/- 9 VDC to +/- 15 VDC			
Connections	BNC signal output. Shielded power cable terminated with a DB-9 connector directly couples the unit with the PS -1 Low Noise Power Supply.			