

## PBSE - SERIES PHOTOCONDUCTOR

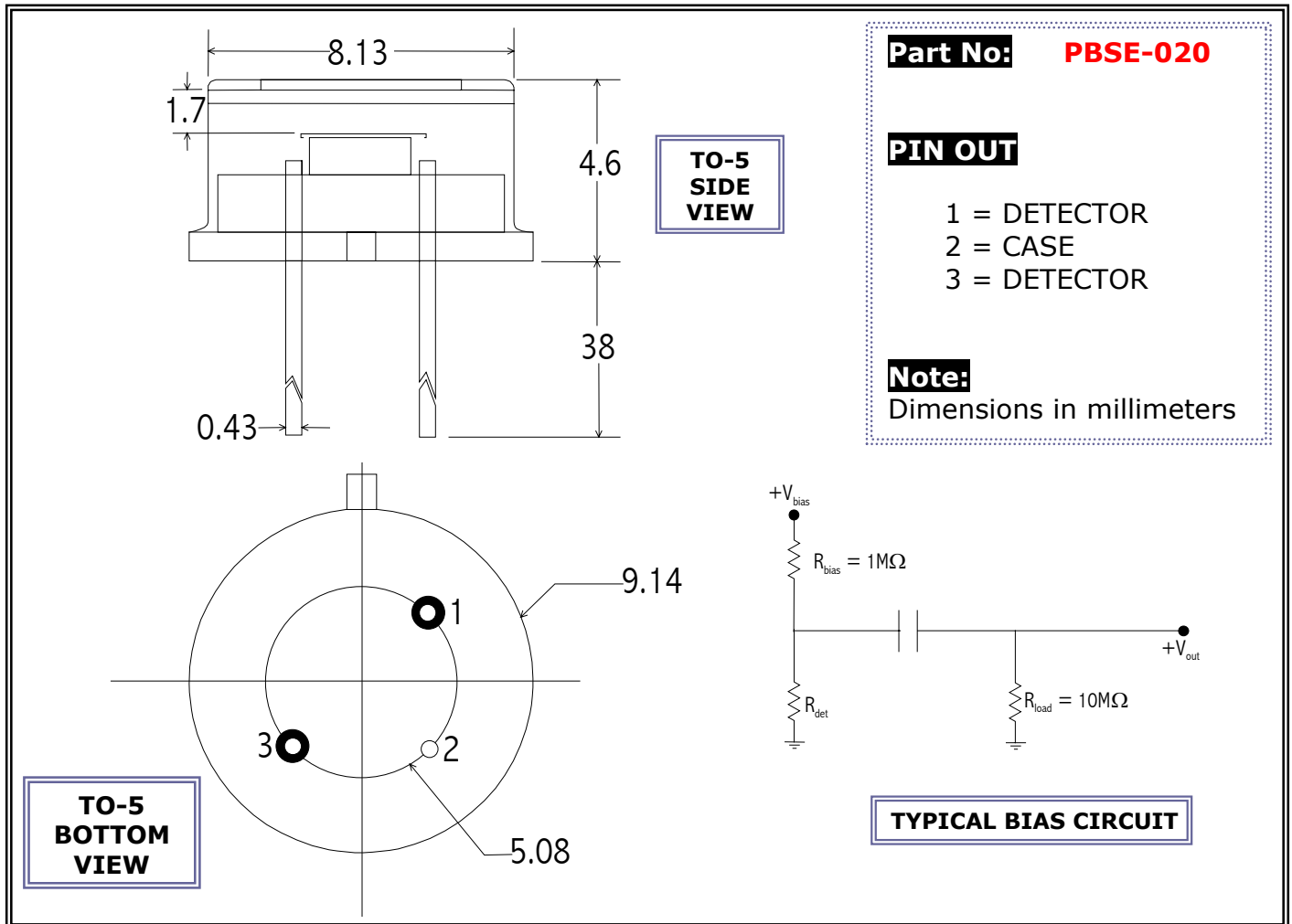

**Application Note** EOS offers room temperature and thermoelectrically cooled photoconductive detectors. The units have state-of-the-art sensitivity and may be supported by accessories such as optical filters (longpass and bandpass), integral preamplifiers, temperature controllers and infrared source assemblies. These units find applications in industrial control systems, gas analyzers, thermal sensors, and general infrared instrumentation.

### SPECIFICATIONS

Active Area	2mm x 2mm
Operating Temperature (°C)	22
Operating Wavelength	1.0 – 4.5 microns
Dark Resistance (MΩ)	0.5 nom
Time Constant (μs)	15 typ
Voltage Bias (V)	100 with 1M series resistor
Responsivity @ $\lambda_p$ (V/W)	≥ 4000
D* @ $\lambda_p$ (cm Hz <sup>1/2</sup> /W)	≥ 5 x 10 <sup>9</sup>