

2 - COLOR PHOTODETECTOR

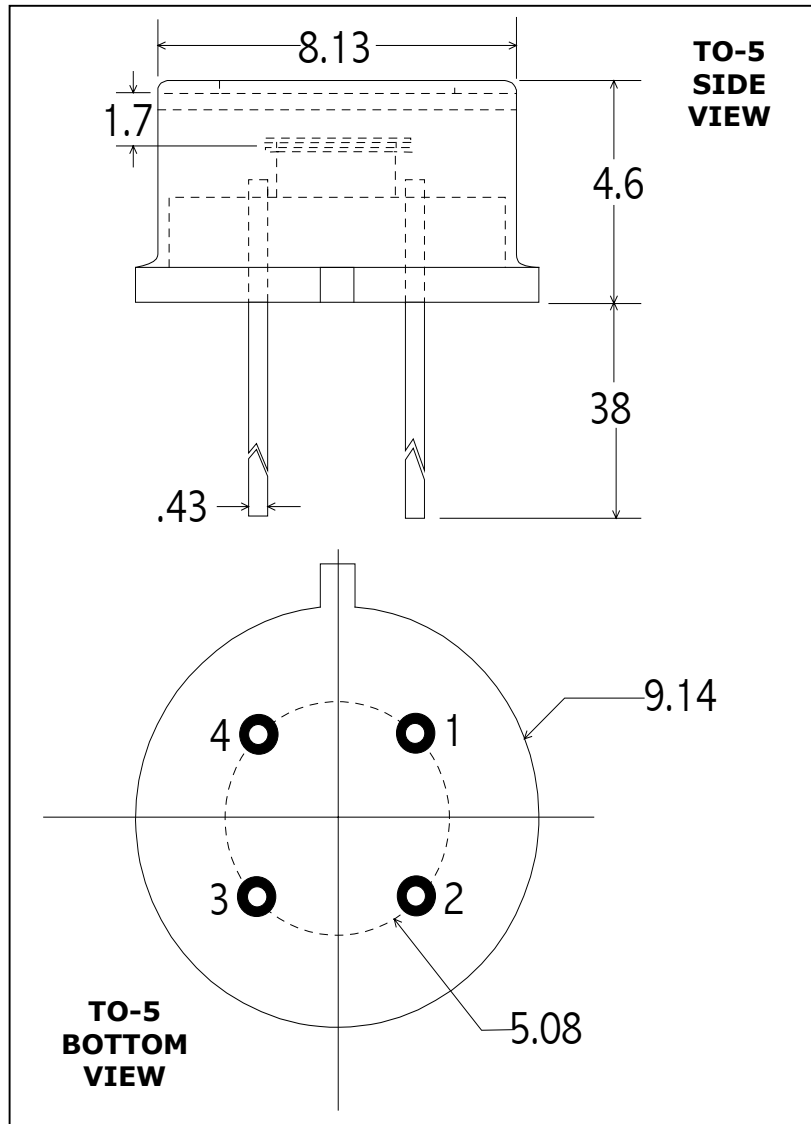

Part No: S/PBSE-025/020

PIN OUT

- 1 = TOP CATHODE
- 2 = TOP ANODE
- 3 = BOTTOM DETECTOR
- 4 = BOTTOM DETECTOR

Note:
Dimensions in millimeters

Application Note

ELECTRO OPTICAL SYSTEMS offers a variety of room temperature 2-color detectors. The units have state-of-the-art sensitivity and are supported by accessories such as optical filters, integral preamplifiers, and fiber optic connectors.

These units find applications in industrial control systems, test equipment, thermal sensors, and general infrared instrumentation.

SPECIFICATIONS

Detector Position	TOP	BOTTOM
Detector Type	Si Photodiode	PbSe Photoconductor
Active Diameter (mm)	2.5	2.0 x 2.0
Operating Wavelength (μm)	0.3 – 1.0	1.0 – 4.5
Shunt Resistance (Ω)	500 M min @ 0V	0.3 – 1.0 M
Shunt Capacitance (pF)	400 typ	N/A
Responsivity	0.55 A/W @ 850 nm	> 2000V/W @ 4.2 μm
NEP (W/Hz ^{1/2})	<1 x10 ⁻¹⁴ @ 850 nm	< 7 x10 ⁻¹¹ @ 4.2 μm