

TE - COOLED PHOTODIODE

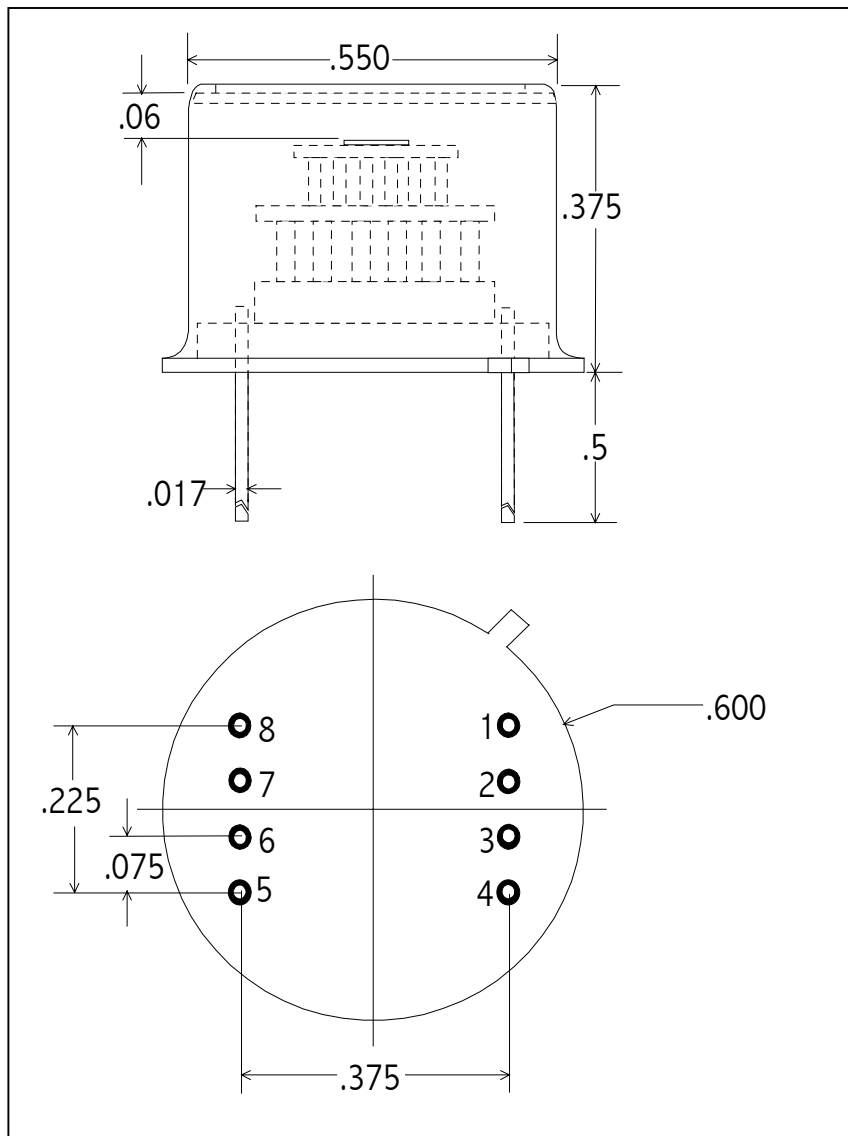

Part No: **UVS-025-TE2**

PIN OUT

- 1 = COOLER (-)
- 2 = THERMISTOR
- 3 = THERMISTOR
- 4 = COOLER (+)
- 5 = DETECTOR CATHODE
- 6 = DETECTOR ANODE
- 7 = NO CONNECT
- 8 = NO CONNECT

Note:
Dimensions in inches

Operating Note

The TE cooled photodiode series consists of a high performance photodiode mounted on a thermoelectric cooler, all housed in a TO-8 package. A thermistor is mounted to the TEC's cold plate to provide a precise, reliable temperature monitor. Before operation VERIFY ELECTRICAL WIRING, else catastrophic damage may be sustained by the unit. Electrical power consumption can exceed 2.5 Watts (2V / 1.25A); therefore, this package must be suitably heat sunk. Thermal grease with secure clamping is recommended for power dissipation. Temperature levels below -45°C are possible with an optimized mechanical assembly.

SPECIFICATIONS

Operating Temperature (°C)	22	-30
Shunt Resistance (MΩ)	200	> 1000
Shunt Capacitance (pF)	300 typ	300 typ
Responsivity @ 800 nm (A/W)	0.55	0.55
NEP @ 800 nm W/Hz ^{1/2}	< 1.5 X 10 ⁻¹⁴	< 10 ⁻¹⁴
Thermistor Resistance (kΩ)	1.8 typ	40 typ
Cooler Current (A)	0.00	0.65 TYP.
Maximum Cooler Current (A)	1.25	